

THE SHOWER LAB

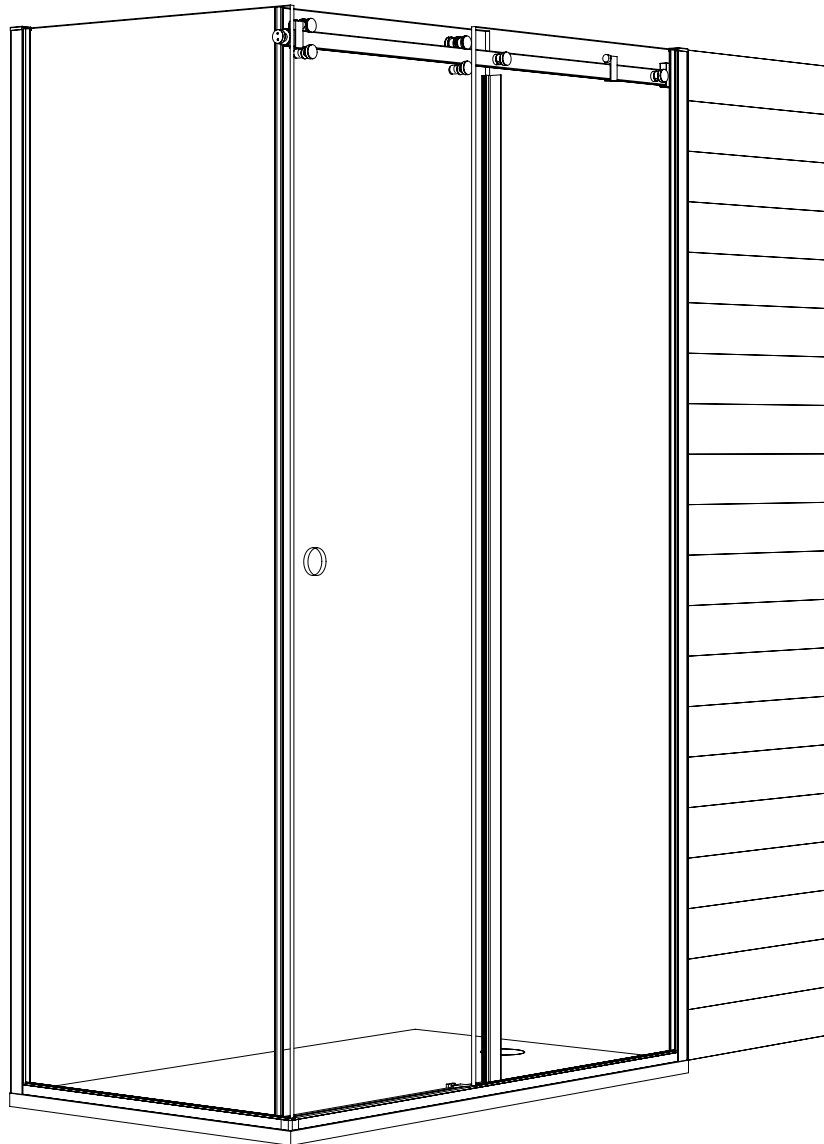

VIEW 31DP



Illustration - View 31DP
Right Hand

IMPORTANT

- This shower screen / enclosure must be installed by suitably qualified individuals. We recommend a minimum of two people for safe assembly of certain sections of this screen.
- Ensure all appropriate safety equipment, especially protective footwear, safety glasses and gloves are used.
- When drilling holes in ceramic tiles, use masking tape to prevent the drill from slipping: DO NOT use hammer action as this will crack the tiles. Use a high quality drill bit to ensure a clean, precise hole.
- Tighten hinges and brackets to the recommended **15.6N**.
- Please leave these instructions with the customer following installation.

PRIOR TO INSTALLATION

- Before disposing of the packaging and prior to commencing assembly, please check all the components to ensure that they have been supplied correctly and are undamaged. Subsequent claims for missing or damaged pieces will not be accepted once the packaging has been disposed of and installation commenced.
- In the event of any queries please contact your supplier quoting the relevant model information.
- The Tray / Tiled floor on which this screen is to be installed must be level on all sides.
- It may be necessary to use alternate fixings to those supplied, depending on the properties of the walls to be fixed to.
- Use the protective corners supplied at all times until the glass is moved to its final position.
- Ensure that the glass is installed correctly, taking care to avoid installing the glass upside down. On certain panels an easy clean coating is applied to one side only, this is clearly marked with a sticker on the non-coated side. The coated surface is to be fitted inwards towards the inside (wet side) of the screen.
- Ensure that all surfaces to be sealed are clean and dry prior to applying the silicone sealant. Use a high grade fungal resistant sealant.
- Allow a minimum of 24 hours after application of the silicone sealant prior to using the screen.

TOOLS & MATERIALS REQUIRED

Junior Hacksaw	Modelling Knife	High Quality Silicone Sealant
Straight Edge (Steel Rule)	Spirit Level	Digital Torque Wrench
Fine Tooth File	Pencil	Tape Measure
Set or Roofing Square	Silicone Gun	Pozi-drive
Masking Tape	Power Drill	Screwdrivers, PZ1&2
	Ø6mm Masonry Drill Bit	Safety Glasses and
	2x Suction Glass Lifters	Gloves

CARE AND MAINTENANCE

(please ensure that these instructions are left with the installed unit)

- We recommend routine cleaning of your screen / enclosure with hot water using a soft cloth, then drying with a dry soft cloth or chamois leather.
Ritec Aftercare for Shower Glass is recommended for best results.
- All glass has been treated with EASY CLEAN glass finish and care must be taken to avoid any abrasive cleaning products that may damage the special surface protection.
- DO NOT use acidic based de-scaler products or products containing bleaches or solvents.

Supplied Parts

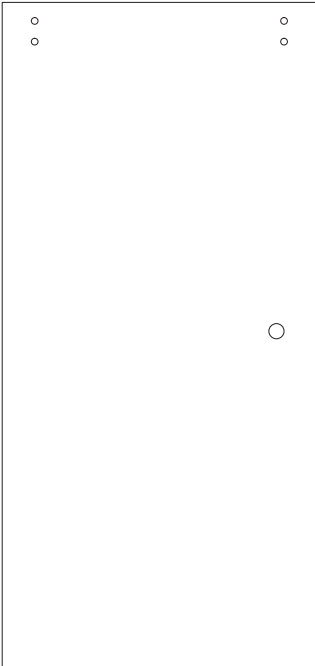

Door
x1

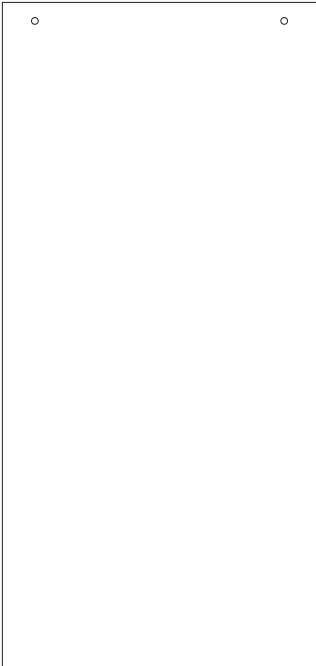

Inline Panel
x1

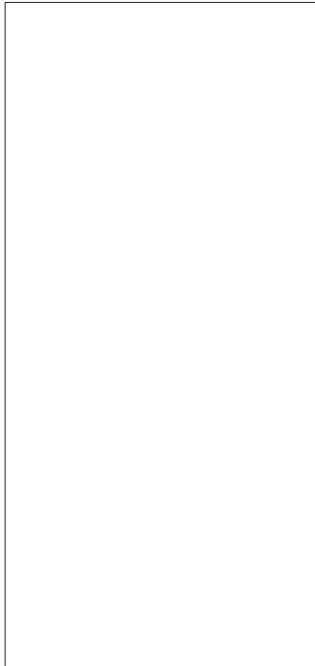

Return Panel
x1

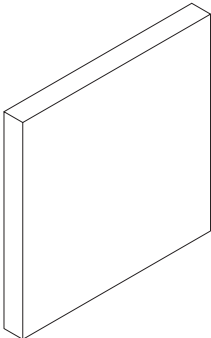

Nylon Block
x1

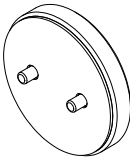

Pig Nose Adapter
x1

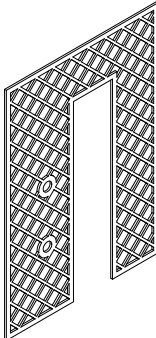

Slider Bracket Template
x1

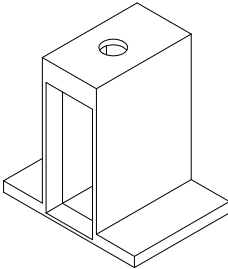

Slider Bar Return Jig
x1

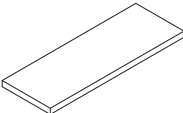

Spacers

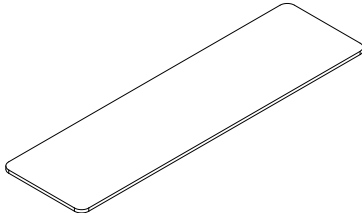

Packers

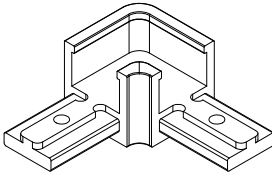

Underframe 90° Connector
x1

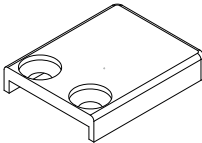

Wall Profile End Cap
x2

Supplied Parts

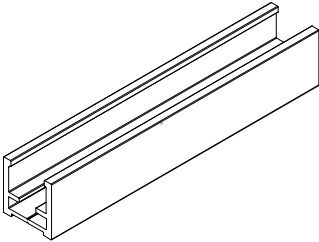

Underframe
x2

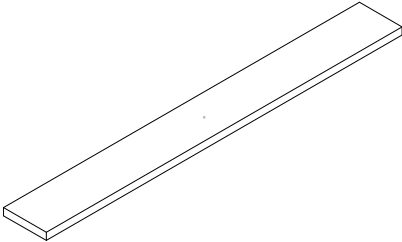

Underframe Gasket
x2

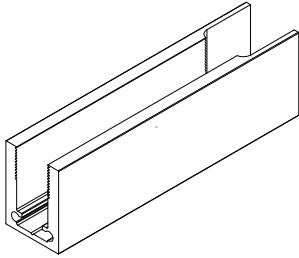

Wall Profile
x2

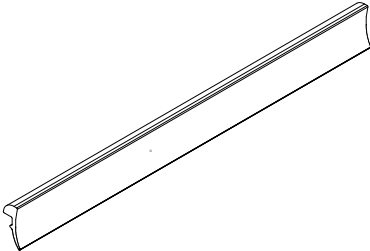

Underframe Wedge Gasket
x4

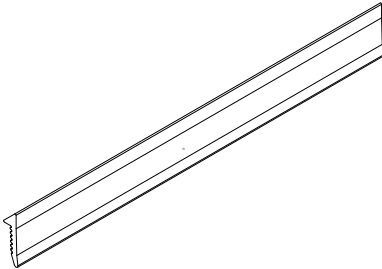

Wall Profile Rigid Seal
x2

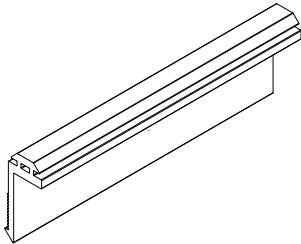

Wall Profile Soft Seal
x2

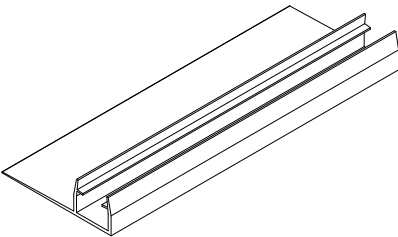

Glass to Glass Slider Seal
x1

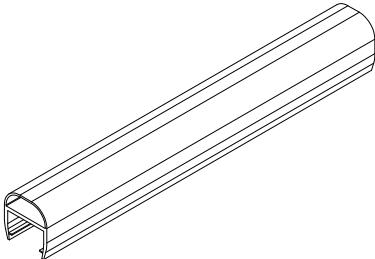

Glass to Wall Seal
x1

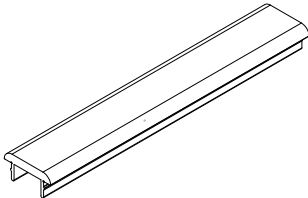

Underframe Top
x1

Supplied Parts

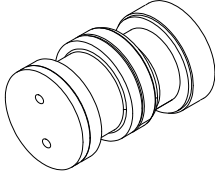

Slider Door Roller
x2

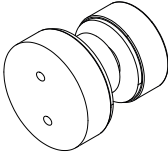

Slider Panel Fixing
x2

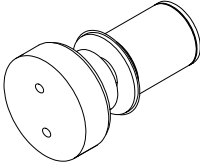

Slider Door Retainer
x2

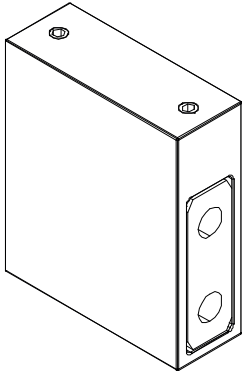

Slider Wall Bracket
x1

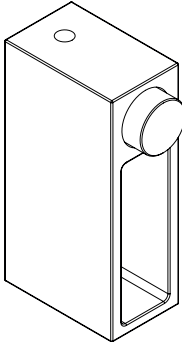

Slider Door Stop
x2

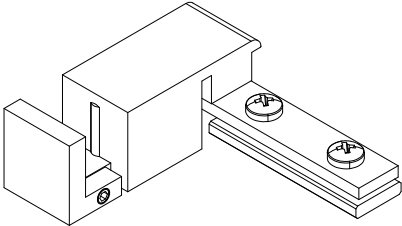

Bottom Door Guide
x1

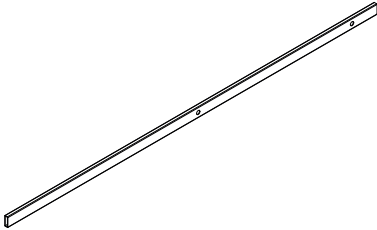

Slider Bar
x1

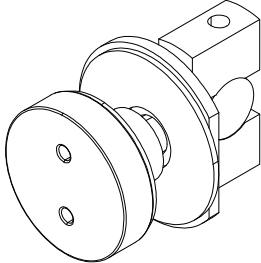

Slider Return Panel Fixing
x1

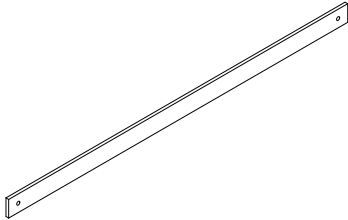

Slider Bar Insert
x1

These instructions are for the View 31DP.

The following instructions are valid for both the 20mm and 30mm profiles. The 30mm profile is used in the following instructions.

Please use the below diagram to reference the list of parts.

- (A) Return Panel
- (B) Door Panel
- (C) Inline Fixed Panel
- (D) Wall Profile
- (E) Wall Profile End Cap
- (F) Wall Profile Soft Seal
- (G) Wall Profile Rigid Seal
- (H) Underframe Wedge Gasket
- (I) Underframe
- (J) Underframe Top
- (K) Underframe 90 Connector
- (L) Underframe Gasket
- (M) Bottom Door Guide
- (N) Glass to Glass Slider Seal
- (O) Glass to Wall Bubble Seal
- (P) Slider Bar
- (Q) Slider Bar Insert
- (R) Slider Door Stop
- (S) Slider Wall Bracket
- (T) Slider Door Retainer
- (U) Slider Door Roller
- (V) Slider Panel Fixing
- (W) Slider Return Panel Fixing

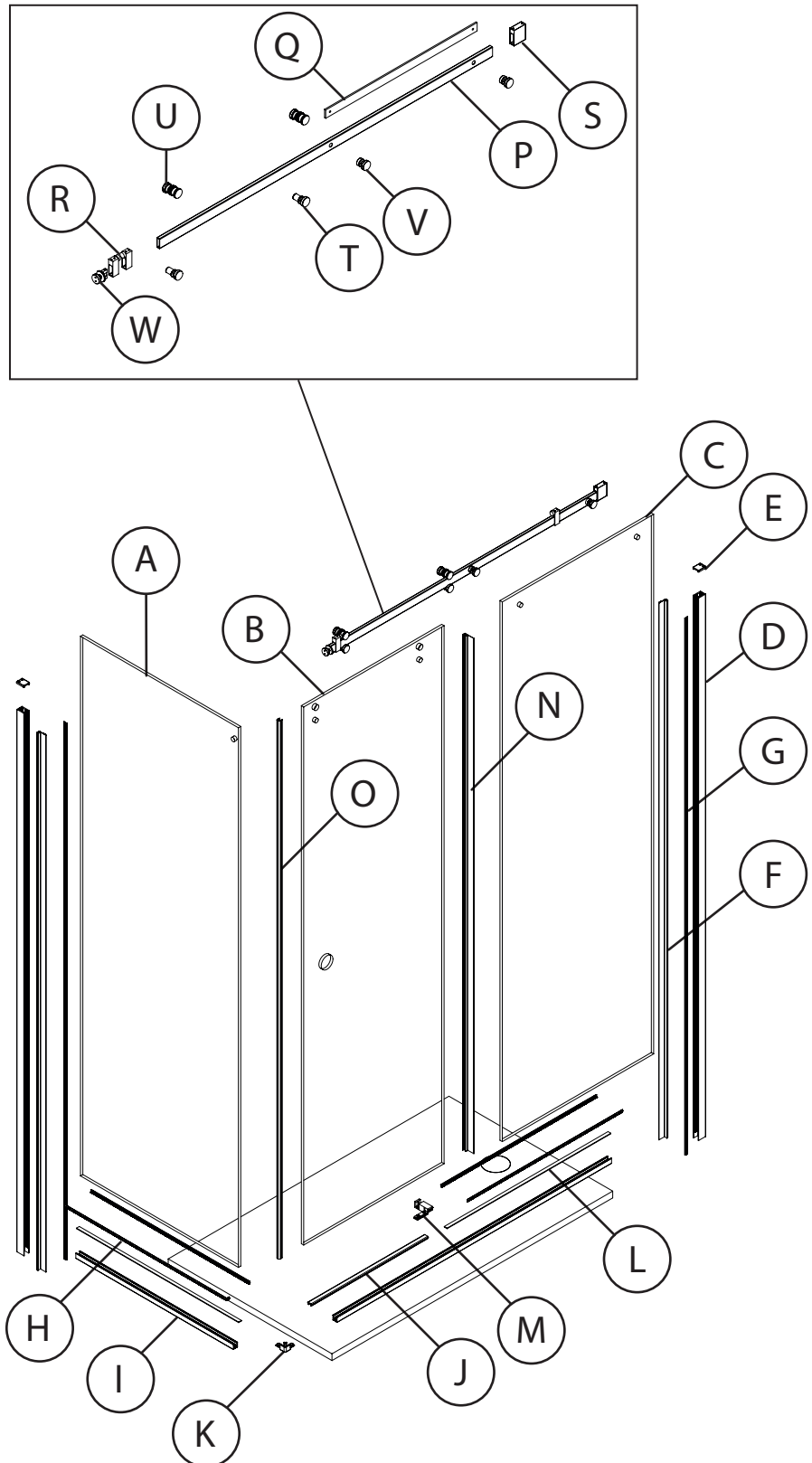

LH

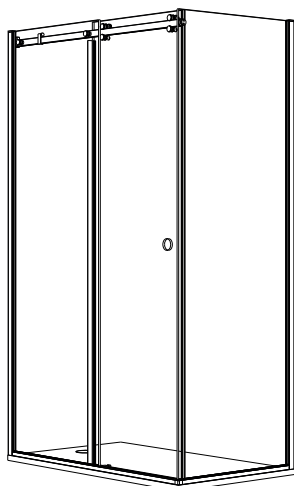

RH

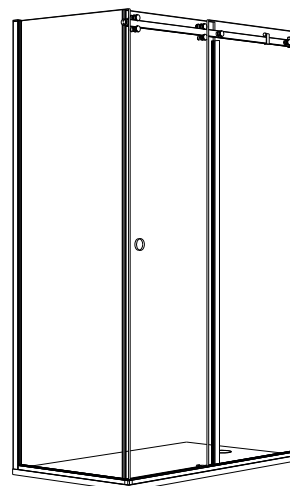

Enclosure dimensions to OUTSIDE of Wall Profiles - See spec below
 Underframe dimensions - (See spec below -3mm Wall Profile Overlap)

STANDARD ENCLOSURES - 30mm (CH30) Wall Profiles

Code	Width	Return	Opening Gap	Overlap	Height	<input checked="" type="checkbox"/>
VR31S11080	1042-1082	774 - 788	430 - 470	70 - 30	2000	<input type="checkbox"/>
VR31S11090	1042-1082	874 - 888	430 - 470	70 - 30	2000	<input type="checkbox"/>
VR31S12080	1142-1182	774 - 788	480 - 520	70 - 30	2000	<input type="checkbox"/>
VR31S12090	1142-1182	874 - 888	480 - 520	70 - 30	2000	<input type="checkbox"/>
VR31S13080	1242-1282	774 - 788	530 - 570	70 - 30	2000	<input type="checkbox"/>
VR31S13090	1242-1282	874 - 888	530 - 570	70 - 30	2000	<input type="checkbox"/>
VR31S14080	1342-1382	774 - 788	580 - 620	71 - 30	2000	<input type="checkbox"/>
VR31S14090	1342-1382	874 - 888	580 - 620	72 - 30	2000	<input type="checkbox"/>
VR31S15080	1442-1482	774 - 788	630 - 670	73 - 30	2000	<input type="checkbox"/>
VR31S15090	1442-1482	874 - 888	630 - 670	74 - 30	2000	<input type="checkbox"/>
VR31S16080	1542-1582	774 - 788	680 - 720	75 - 30	2000	<input type="checkbox"/>
VR31S16090	1542-1582	874 - 888	680 - 720	76 - 30	2000	<input type="checkbox"/>

BESPOKE ENCLOSURES - 30mm (CH30)/ 20mm (CH20) Wall Profiles

If you have a Bespoke Enclosure, reference the Install Sheet for the panel specifications of the Enclosure.
CH30 - Bespoke Front Width: Door + Panel - 44 = Minimum Width + 54 = Maximum Width
CH30 - Bespoke Return Width: Panel + 17 = Minimum Width + 14 = Maximum Width
CH20 - Bespoke Front Width: Door + Panel - 44 = Minimum Width + 44 = Maximum Width
CH20 - Bespoke Return Width: Panel + 17 = Minimum Width + 4 = Maximum Width

01 Position the Underframe parallel to tray edge. If using a raised shower tray, leave a minimum 3mm gap from the edge of the tray (5mm is recommended).

Use tape to mark this dimension.

Repeat for the Return Underframe Profile.

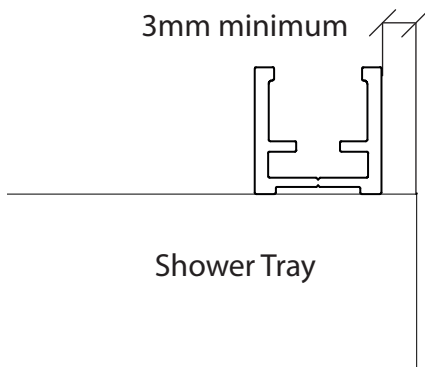

02 Measure the distance from the tape edge to the tiling and take note of this distance.

Repeat for the Return Underframe.

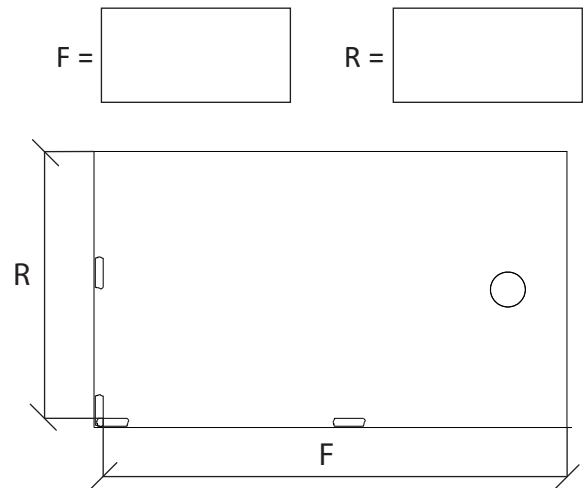

03 Check the dimensions are within the allowed adjustments by referencing the attached adjustment sheet.

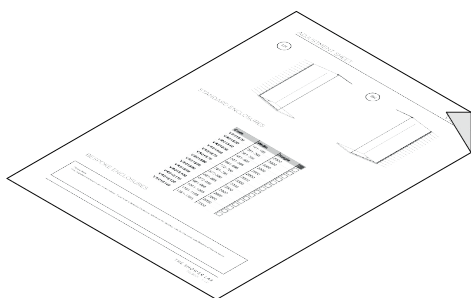

04 Subtract 22mm from the Front and Return Underframe dimension. This is the profile width. Mark this measurement on the Underframe.

Cut squarely using a chop saw.

Use a fine toothed file to remove any burrs, be careful not to damage the surface finish.

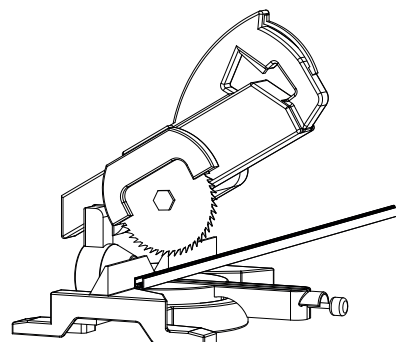
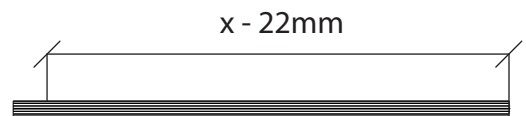

05

Slide the Bottom Door Guide Fixing Plate into the T Slot of the Front Underframe profile.



IMPORTANT STEP

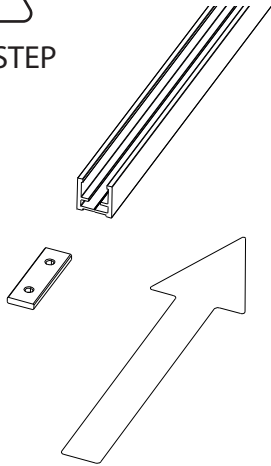

06

Connect the Underframe Profiles together using the Underframe 90° Connector and supplied screws.

Add a small amount of silicone to the ends of the Underframe before connecting.

Remove the backing strips from the self adhesive and fix firmly to the tray.

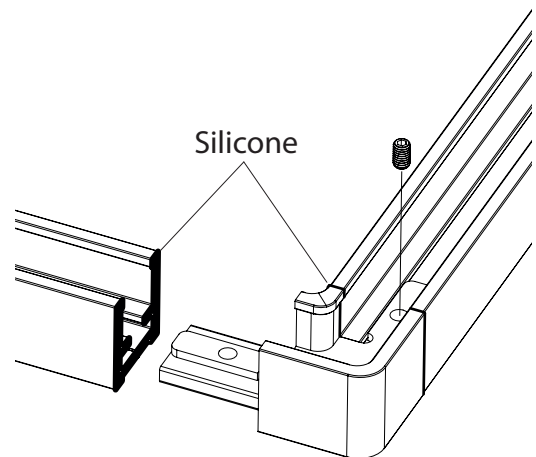

07

Place the Underframe Gaskets where the glass will sit into the Underframe and butt up against the wall.

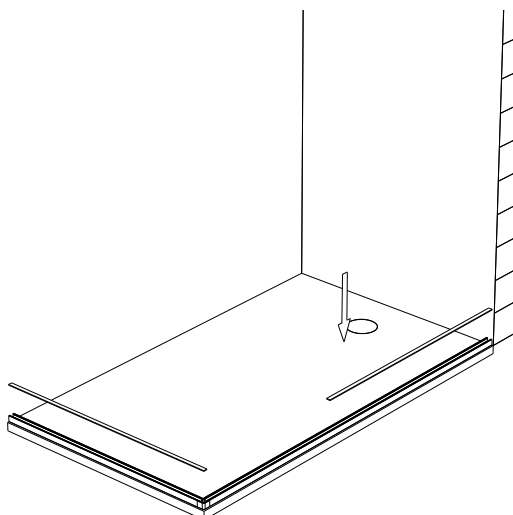

08

Place the Wall Profiles over the Underframe and up against the wall.

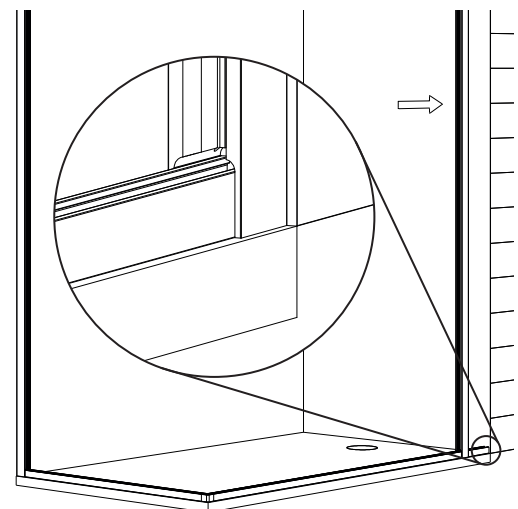
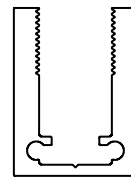

09 Ensure the Wall Profiles are vertical by using a spirit level. Mark the positions of the pre-drilled holes.

10 Remove the Wall Profiles and drill holes on each wall with a 6mm high quality drill bit for a clean and precise hole.

Fully insert the wall plugs.

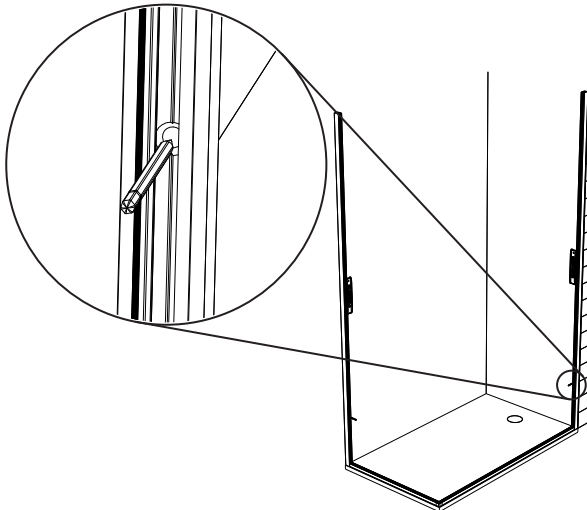

Professional Tip
If drilling ceramic tiles, place masking tape on the tiles before marking and drill through the tape to prevent the drill bit from skidding.

DO NOT use Hammer Action as this will break the tiles.



11 Pre drill the No 6 screws in to the Wall Profile to create the thread for the Top Cap, then REMOVE screws.

12 Take the Wall Profile Soft Seal and push the seal into place on each Wall Profile to cover the screws.

Fix the Wall Profiles to the wall using the No 8 screws.

Ensure the fin is on the inside (wet side).

Use the Nylon Block to help.

-  (No 8) Profile - Wall
-  (No 6) Profile - Top Cap

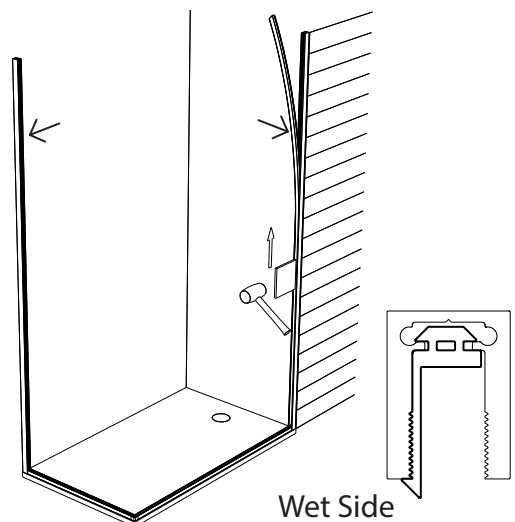
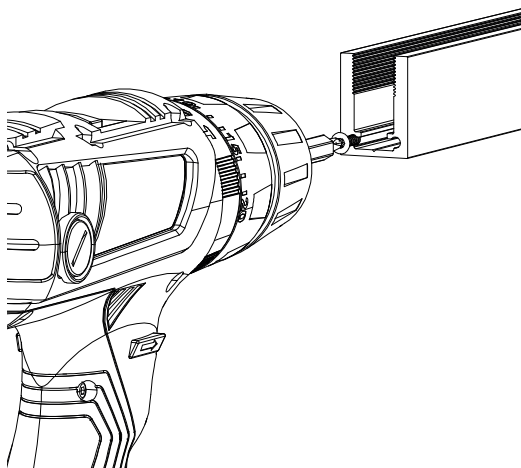

13

Using purpose built "Glass Lifters", position and sit the Return Glass Panel on to the Underframe Gasket and push against the Wall Profile.

Note the orientation and position of the Panel, this can be determined by any holes or attached labels.



14

Remove and replace the Panel adding or subtracting spacers as necessary to level the Panel (to a maximum height of 5mm inside the Underframe).

Check the Panel is level using a Spirit Level.



15

Align the Return Panel so there is a 4mm gap between the Panel and the front face of the Front Underframe.

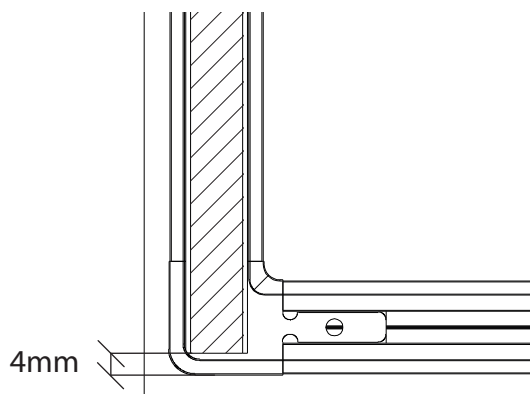

16

Using purpose built "Glass Lifters", carefully place the Inline Panel on to the Underframe Gasket and push against the Wall Profile.

Note the orientation and position of the Panel, this can be determined by any holes or attached labels.

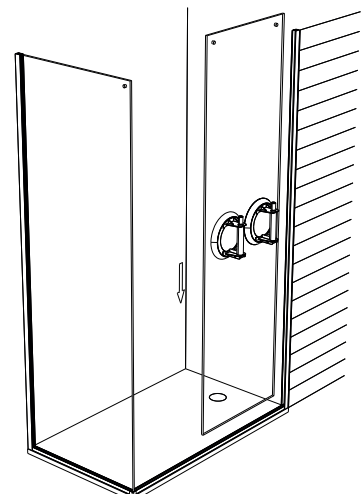

17

Remove and replace the Panel adding or subtracting spacers as necessary to level the Panel (to a maximum height of 5mm inside the Underframe).

Check the Panel is level using a Spirit Level.

If the difference between the two Panels is greater than 5mm, it may be necessary to lower the Return Panel.

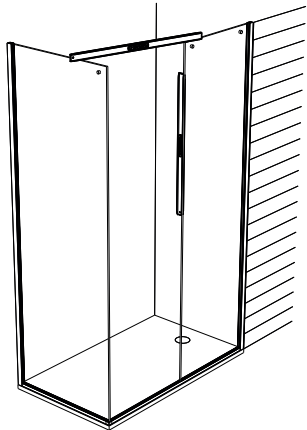

18

If the Wall Profiles are flush with the Glass Panels, move on to step 21.

If the Wall Profiles are not flush with the top of the Glass Panels, mark the Wall Profile. Using a straight edge, mark where the wall channel needs to be trimmed.

To protect the channel finish, it is recommended to mark on masking tape.

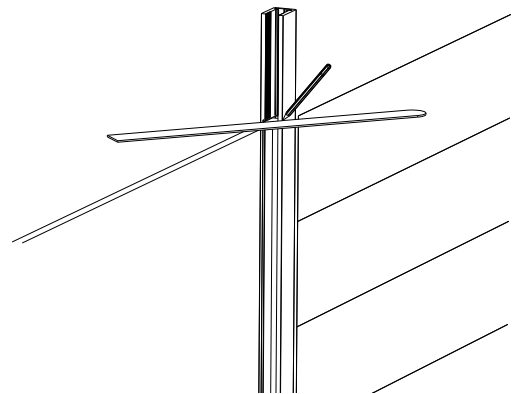

19

Remove the Panels, Wall Profile Soft Seals, and the Wall Profiles.

Trim the Wall Profile.

Use a fine file to remove any burrs. Be careful not to damage the channel finish.

Re drill the screws in to the Wall Profile and remove after drilling.

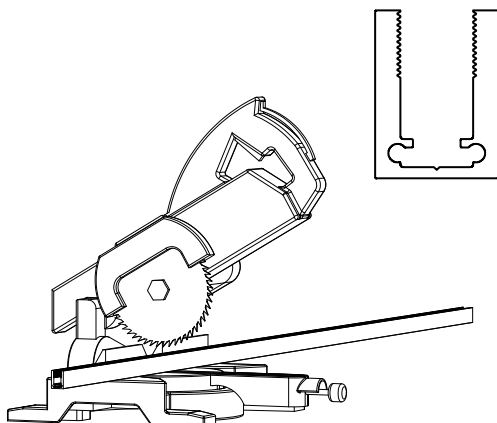

20

Reinstall the Wall Profiles and Wall Profile Soft Seals.



Add silicone in the corner where the Wall profile Meets the Underframe at the back.

Re-install the Glass.

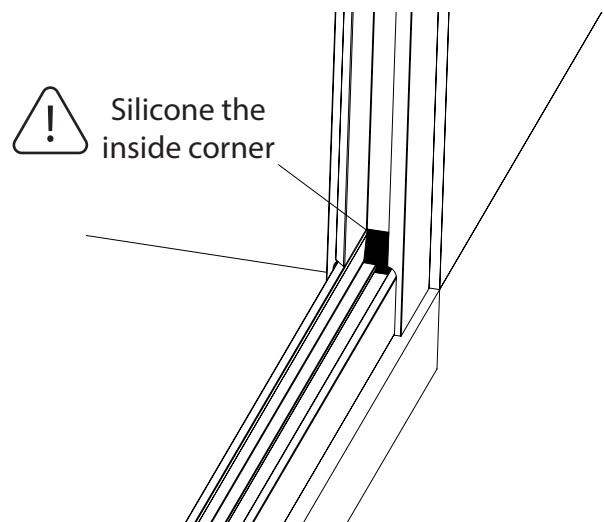

21

Measure the width of the Door.
Measure the distance from the edge of the Inline Panel to the inside face of the Return Panel.

Ensure the door is at least 30mm wider than the gap by adjusting the Inline Panel.

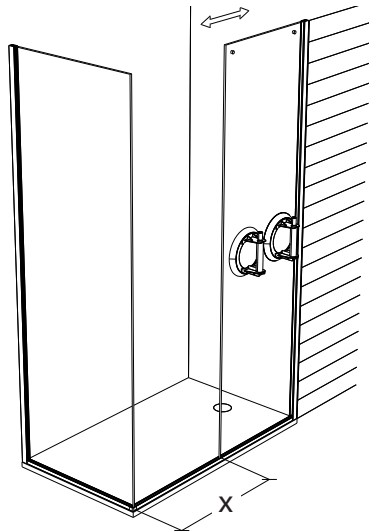

22

Measure and check the distance from the Inline Panel to the Return Panel at the bottom and at the top are equal.

To centre the panel, add 1mm Packers on both sides of Inline Panel and Return Panel in the Underframe.

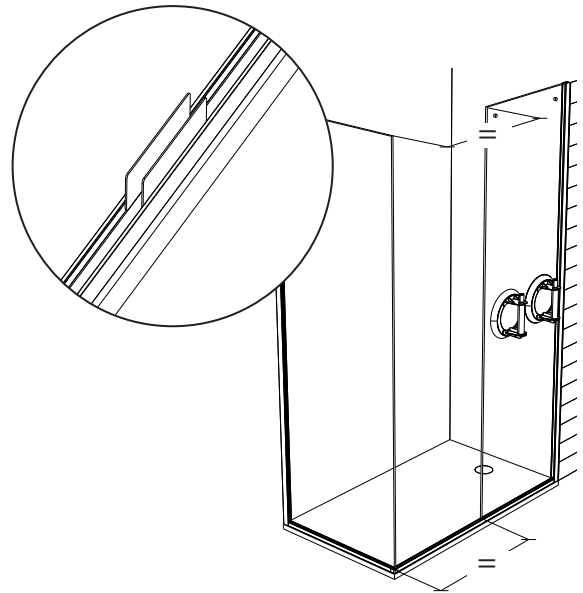

23

Ensure there is adequate glass in both the Wall Profiles. (6mm is recommended)

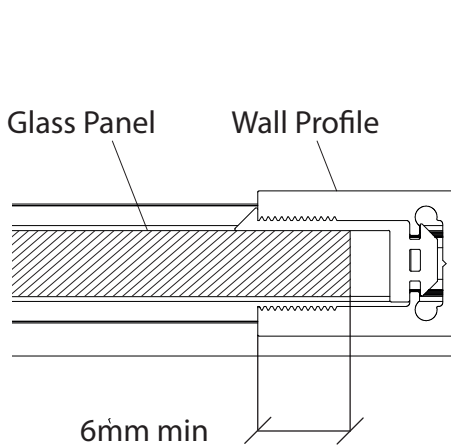

24

Apply the Rigid Seals to the dry side of the Wall Profiles starting from the archway of the Wall Profile up to the top.

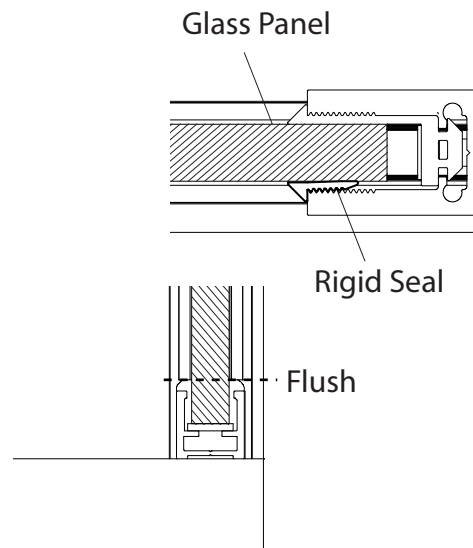

25

Gently tap the Wall Profile Rigid Seal into place using a rubber mallet with the Nylon Block to protect the Glass and the Wall Profile.

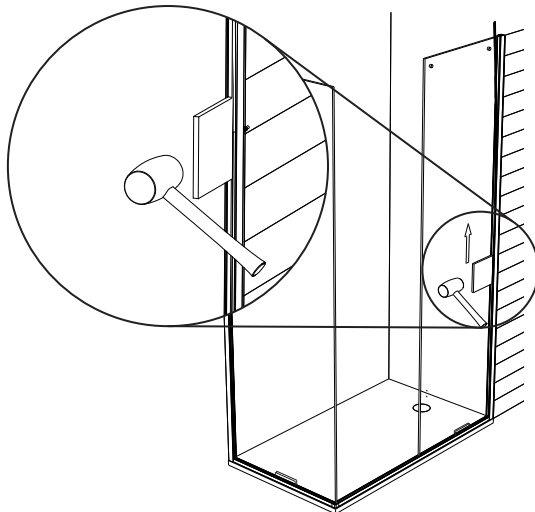

26

Remove Inline Packers and feed the Underframe Wedge Gasket into the archway gap of the Front Inline Panel and trace along the Glass on both sides.

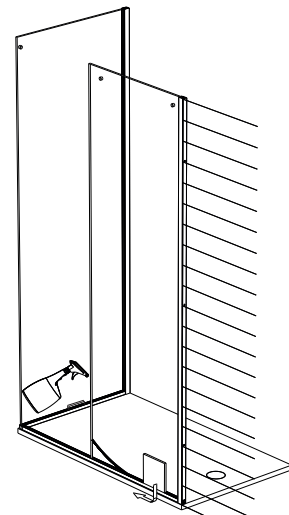

27

Trim the Wedge Gaskets at the edge of the Inline Panel.

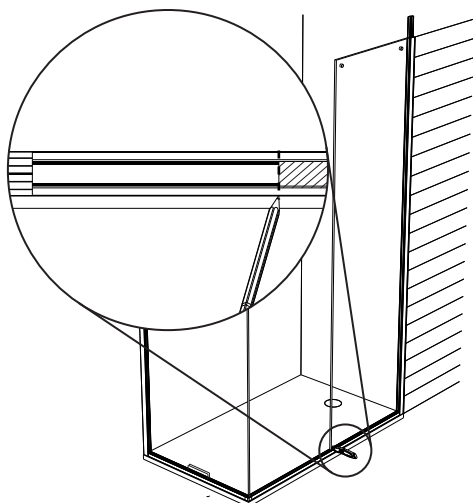

28

Trim both of the Wall Profile seals at the top face of each Wall Profile using a blade.dimension.

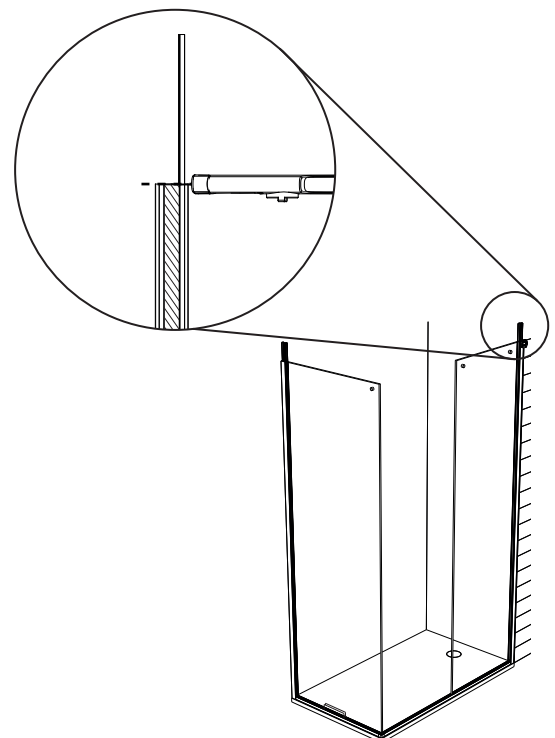

29

Measure the distance from the wall to the nearest fixing hole on the Inline Panel. Ensure this measurement is truly horizontal.

Subtract 15mm to get your final dimension.

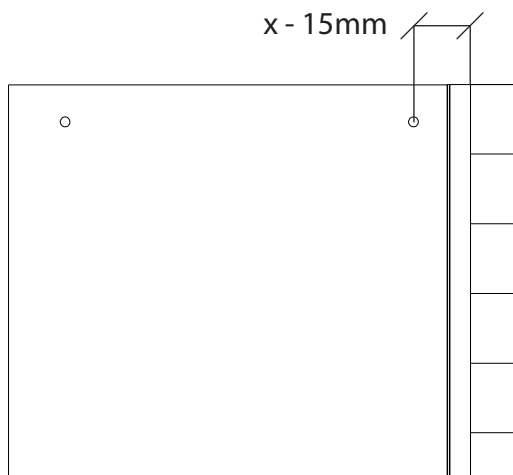

30

Mark the final dimension on the Slider Bar on the fixing hole side.

Cut squarely using a chop saw and finish the edge.



SLIDER BAR IS STAINLESS STEEL

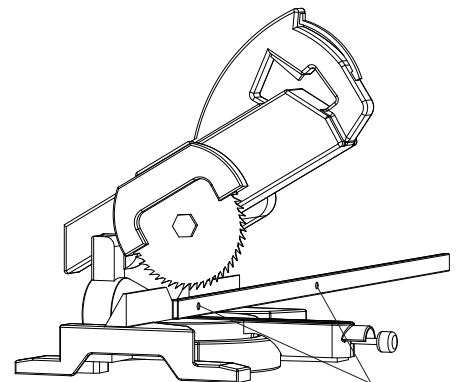

Fixing Holes

31

Use the Slider Rail Bracket Template to mark the hole positions for the Slider Rail Bracket on the Wall Profile side of the enclosure.

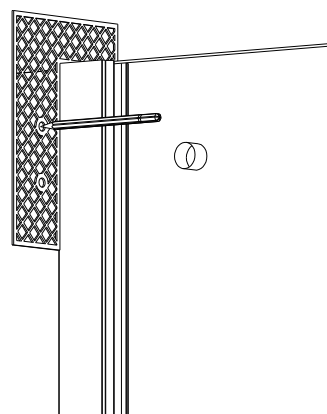

32

Using a $\varnothing 6$ mm high quality drill bit for a clean and precise hole, drill all holes and fully insert the wall plugs.

Fix the Slider Wall Bracket in place using the supplied screws.

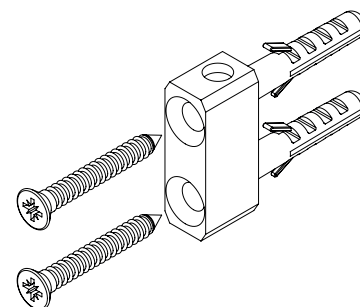

33

Measure the distance from the wall to the inside face of the Return Panel. Ensure this measurement is truly horizontal.

Subtract 18mm to get your final dimension.

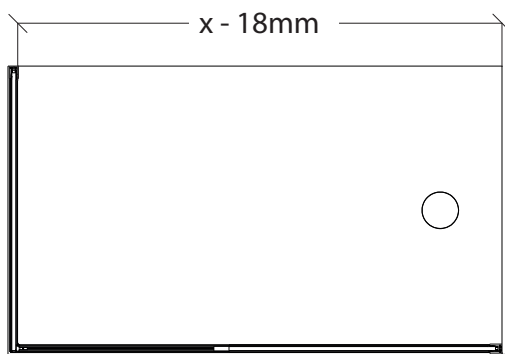

34

Mark the final dimension on the Slider Bar on the opposite side of the Slider Bar.

Cut squarely using a chop saw and finish the edge.



SLIDER BAR IS STAINLESS STEEL

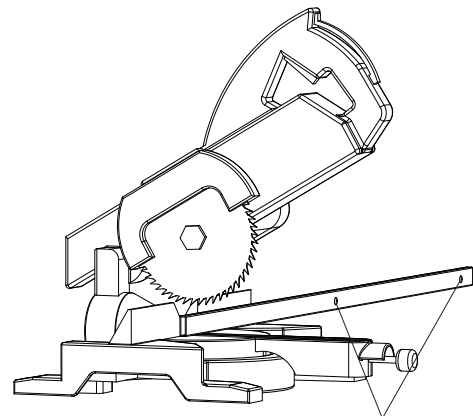
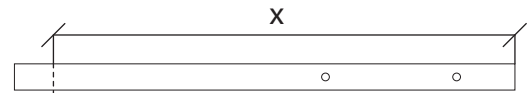

Fixing Holes

35

With masking tape applied, place the supplied Slider Bar Jig firmly at the trimmed end of the Stay Bar and mark the hole with a pen.

Drill holes using a 5mm drill bit.

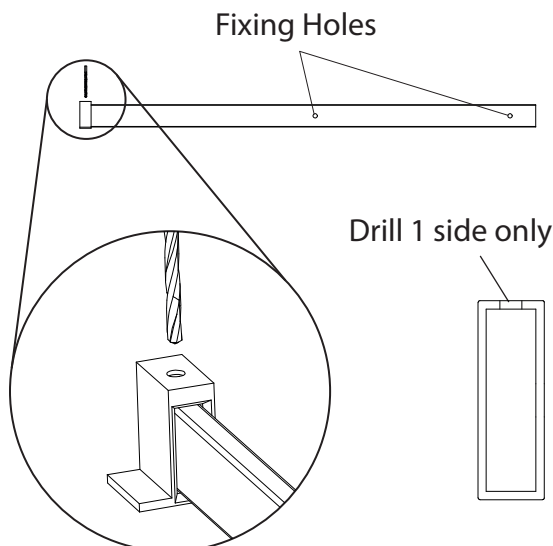

36

Insert the Slider Bar Insert into the Slider Bar and ensure that the threaded holes in the Slider Bar Insert align with the clearance holes on the Slider Bar.

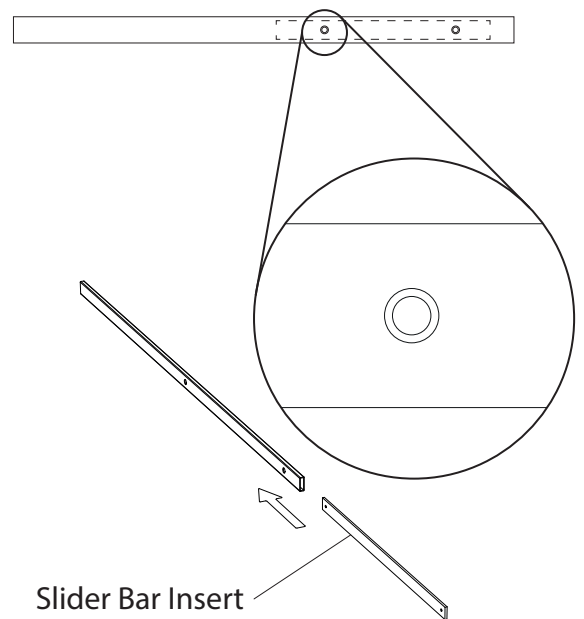

- 37 Use the supplied Pan Head Screw to fix the Slider Return Panel Fixing Bracket into the Slider Bar.

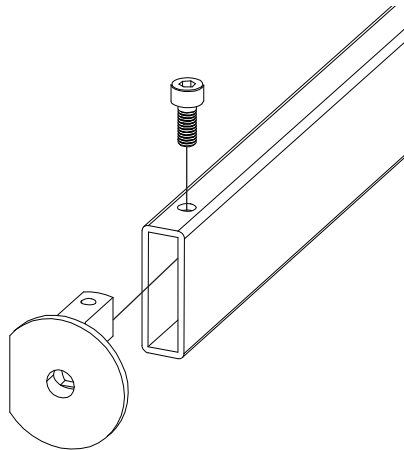

- 38 Slide the Collar over the Wall Bracket and fix in place.



Ensure the Door Stops are positioned and orientated as shown before installing the bar. The stops will be adjusted in a later step.

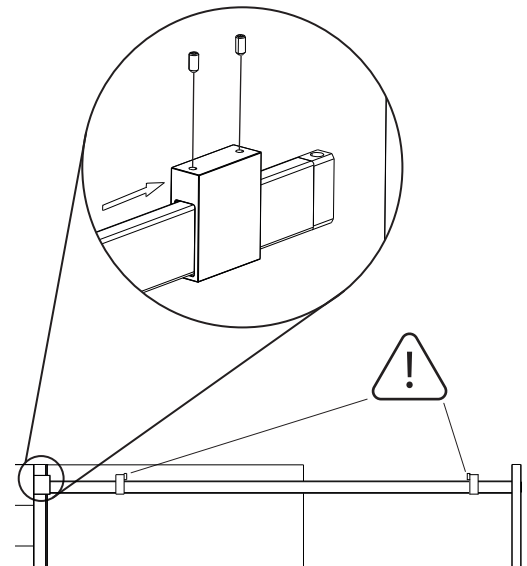

- 39 Fix the Slider Return Panel Fixing to the Return Panel using the Pig Nose Adapter.

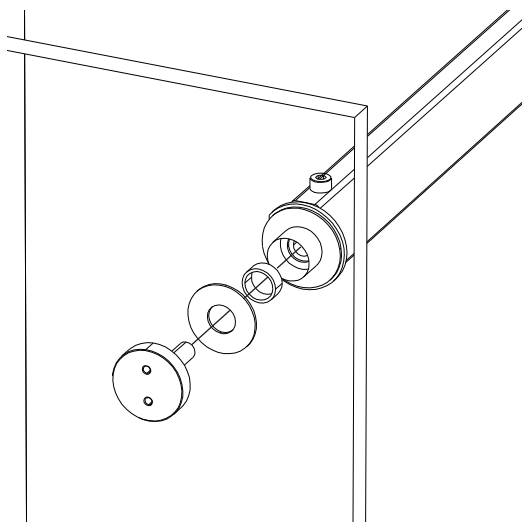

- 40 Fix the Inline Panel to the Slider Bar using the supplied Fixed Panel Fixings.

Use the supplied Pig Nose Adapter to fix in place.

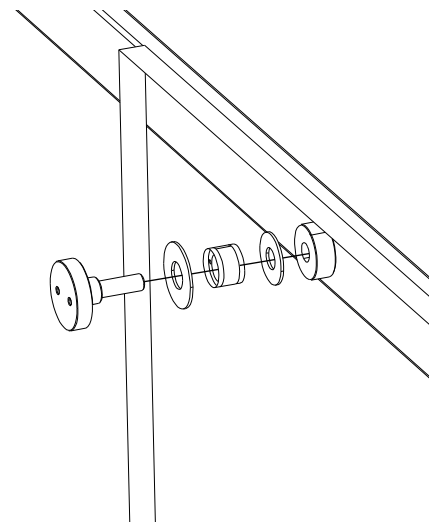

41

Install the Bottom Door Guide to the Underframe by fixing the supplied screws into the Bottom Door Guide Plate.

Ensure that the Bottom Door Guide butts up against the Inline Panel.

Your Guide may be fully assembled. Rotate the Fixing Plate if needed using the 2x PZ1 screws.

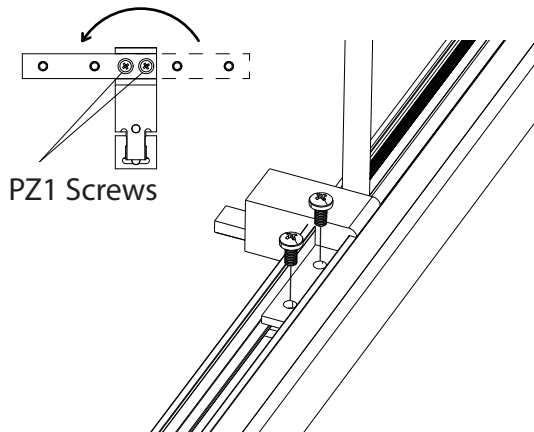

42

Use the Pig Nose Adapter to fix the Top Rollers on to the Door.

Using purpose built "Glass Lifters", carefully position the Door Panel on the Slider.

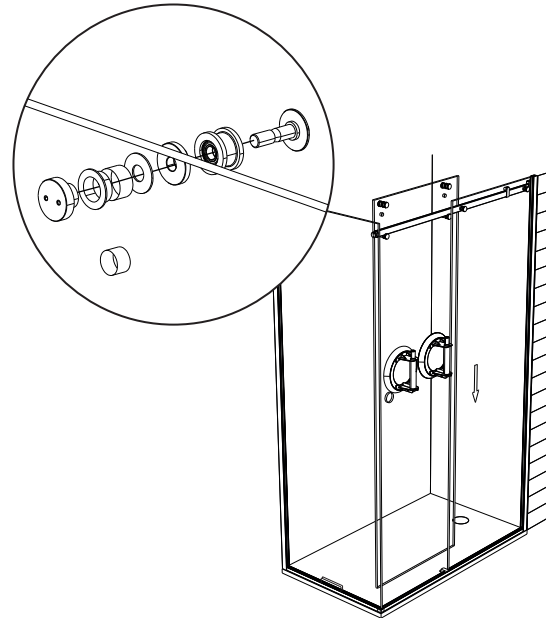

43

Ensure that the Door is level by adjusting the eccentric runners.

Use two allen keys and the supplied Pig Nose Adapter to adjust.

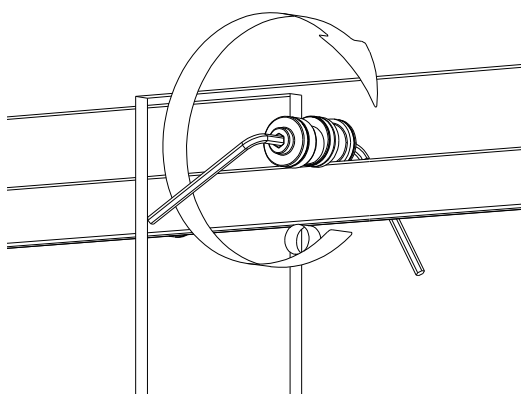

44

Use the supplied Pig Nose Adapter to fix the Bottom Door Retainers in place.



Adjust the Retainers under the Slider Bar so the door is safely locked in.

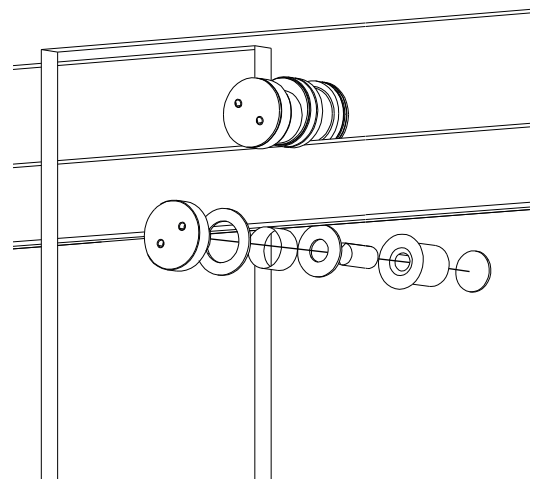

45 Fix the Bottom Door Guide bracket in place using the supplied Grub Screws.

Ensure that the Bottom Door Guide Bracket is lightly touching the Door before fixing in place.

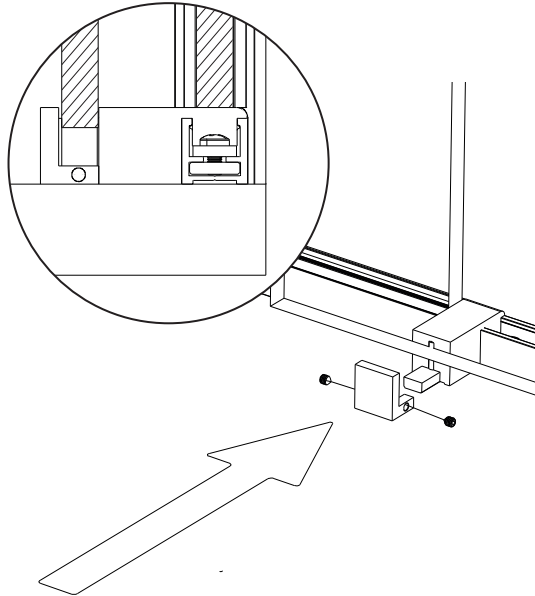

46 Adjust the Door Stops to ensure the Door does not impact the Return panel and handle does not impact the Fixed Inline Panel. Ensure the Bubble seal has sufficient pressure when closing.

Fix in place by tightening the Grub Screws located on top of the Door Stop.

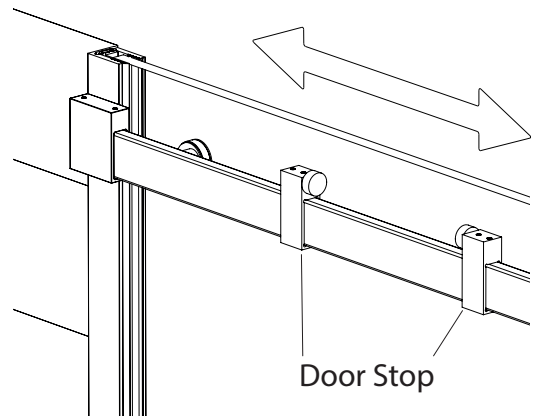

47 Measure the distance between the wall and the edge of the Bottom Door Guide.

Mark and cut the Underframe Top.

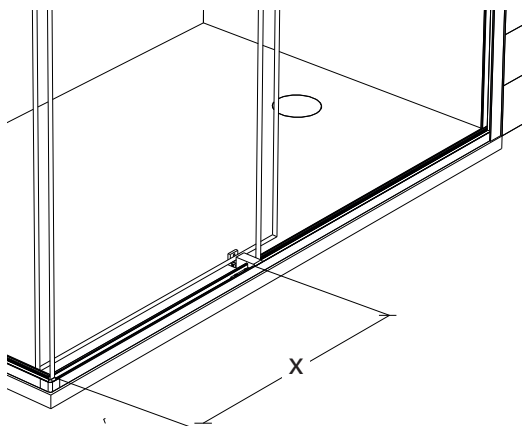

48 Snap the Underframe Top on to the Underframe.

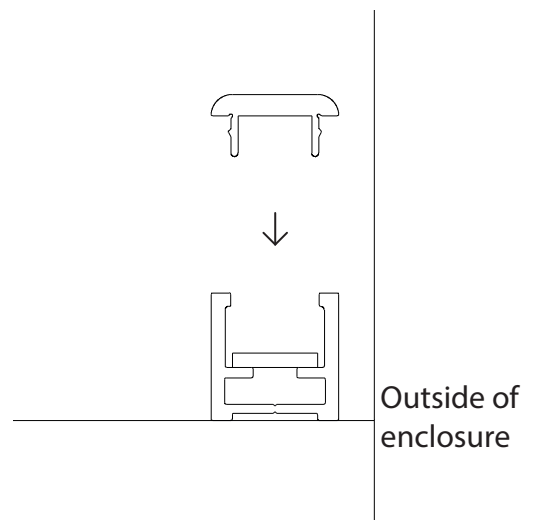

49

Remove Return Panel Packers and feed the Underframe Wedge Gasket into the archway gap of the Return Panel and trace along the Glass on both sides.

Trim the Wedge Gasket where it meets the Underframe Top.

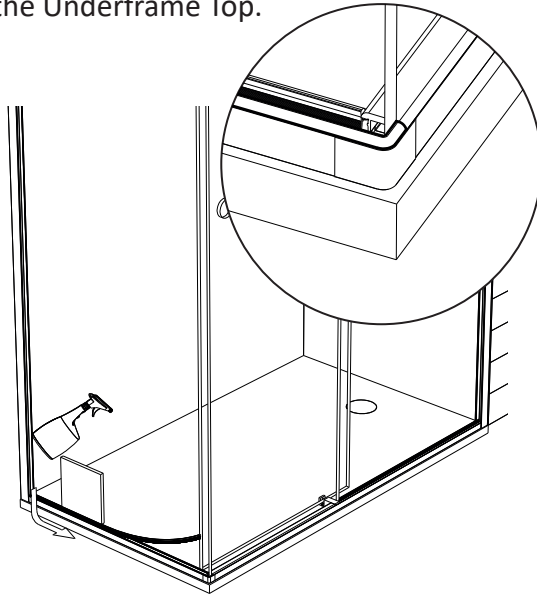

50

Attach the Glass to Wall Bubble Seal to the Door.

Leave the Seal oversized. This will be trimmed later.

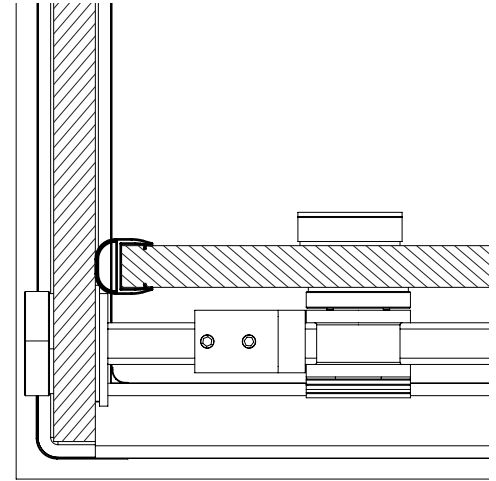

51

Attach the Glass to Glass Slider Seal to the Door.

Check the orientation is correct.

Leave the Seal oversized. This will be trimmed later.

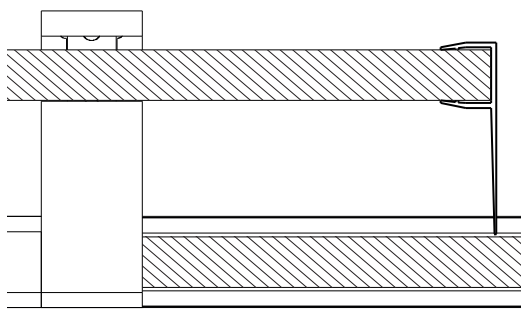

52

Push both Vertical Seals down as far as they can go. With a straight edge, mark where the Seals will be trimmed.

Mark the Glass to Glass Slider Seal just below the Slider Bar.

Remove the Seals and trim with a fine toothed hacksaw so they are flush with the tops of the Door.

Replace the Seals.

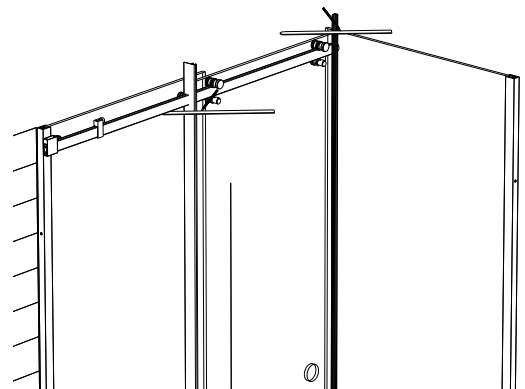

53 Apply the Wall Profile End Cap to the top of the Wall Profile and fix in place using self tapping screws.

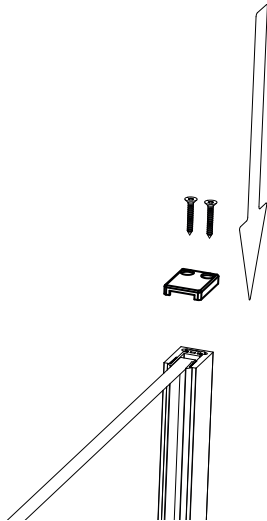

54 Apply silicone sealant along the wall and floor, all around the outside of the Underframe and Wall Profiles.

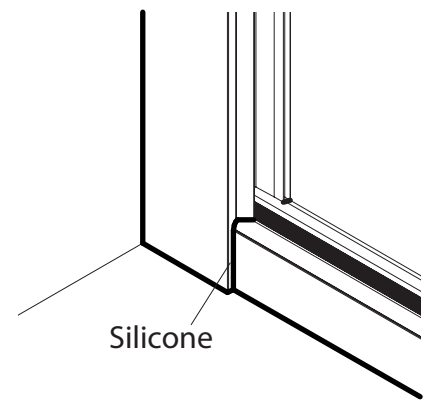
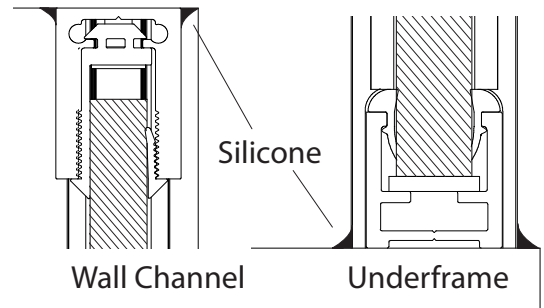

55 Apply silicone to the edges of the Underframe Top where it meets the Glass Inline Panel and the Return Panel.

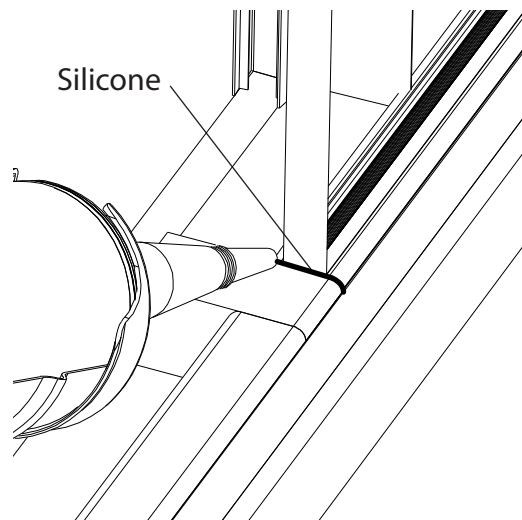

56

Check silicone has been applied to all the below outside areas.

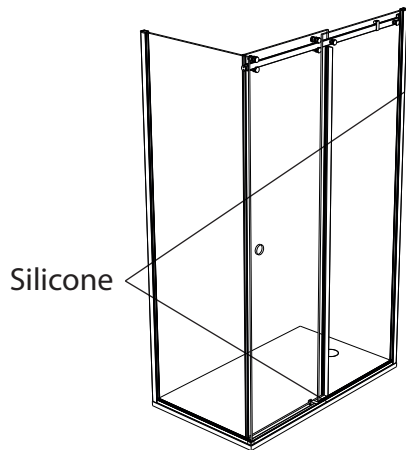

57

Check silicone has been applied to all the below inside areas.

Let the silicone sealant cure for 24 hours.

